



Rangy Enterprise, Inc.

13831 S.W. 59 Street, No 202, Miami, FL 33183.
Tel : (305) 382-3432. Fax : (305) 382-6274.
email : rangy@rangy.com

LAMPARAS INDUSTRIALES

LAMPARAS FIJAS PARA DESCARGAR CONTENEDORES

Dock lights for the loading dock area are rugged, durable, and dependable. Our dock lights help increase safety by providing floods of soft, bright light to illuminate truck and train interiors. Dock lights help increase personnel safety and help eliminate product damage.

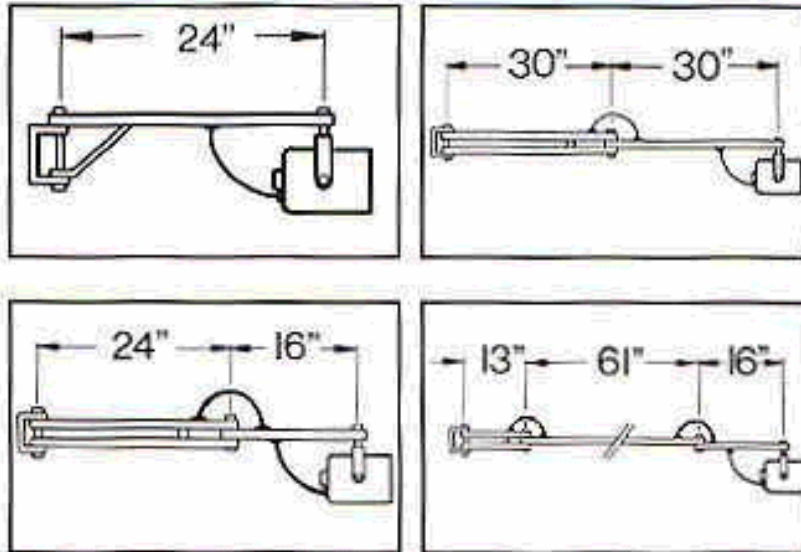

Precio de Lista (L-624, 24"): US\$ 100.00 C/ U

VENTILADORES INDUSTRIALES

VENTILADORES DE PANEL (DIRECT DRIVE)

- Applications: General Ventilating and industrial Mildly Dirty Airstreams
- Operating Range: To 58,000CFM
- Static Pressures to 2" wg
- Fan Sizes From 13-7/8" to 49-5/8"
- Temperatures to 150° F
- Efficiencies to 70% using propellers with three to twelve adjustable blades
- Selections match most efficient propellers to ready available motors
- High efficiency airfoil bladed wheel
- Precision molded high-strength blades
- Compact direct drive configuration
- Heavy steel panel flanged or rigidity
- AMCA Certified for air performance



Precio de Lista (14-4BL, Capacidad 2000CFM): US\$ 374.00
(36-9CL, Capacidad 10,000CFM): US\$ 1,030.00



Rangy Enterprise, Inc.

13831 S.W. 59 Street, No 202, Miami, FL 33183.
Tel : (305) 382-3432. Fax : (305) 382-6274.
email : rangy@rangy.com

VENTILADORES PORTATILES (DIRECT DRIVE)

Wire safety guard encloses aluminum blades
10' power cord and on/ off switch
Equipped with 8" rubber wheels and plastic hubs
0.33 HP, 115 V.
Diameter inches: 30
CFM High and Low: 7,400

Precio de Lista: US\$ 298.00



VENTILADORES DE PEDESTAL (DIRECT DRIVE)

- 24" diameter
- 90° oscilation sweep
- 3 blade aluminium propellers
- Chrome plated safety guards
- 110 volt
- 3 speed function
- 18' long- 3 conductor cord and plug
- 1/4 HP, 6000-4800/4100 CFM
- 46" to 74" height adjustment

Precio de Lista: US\$ 184.00

